

THERMAL CHARACTERISATION OF EDGE CONSTRUCTIONS IN GLAZINGS

S. ERIKSEN, J. KRAGH and S. SVENDSEN¹

Technical University of Denmark, Department of Civil Engineering (BYG•DTU),
Brovej, 2800 Kgs. Lyngby, Denmark

Abstract— The paper presents two methods for thermal characterisation of edge constructions in glazings. The two methods enable a simplified and a detailed determination of the linear thermal transmittance of glazing/frame junction. The detailed method consists of computer calculations with a box-model that yields the linear thermal transmittance and the temperature on the lower part of the inner glazing used to evaluate the risk of condensation. The simple method yields a unique characterisation of the edge construction valid for different frame profiles that allows a simple determination of the linear thermal transmittance based on a thermal characteristic value of the edge construction. For the calculation of the linear thermal transmittance and temperatures the computer tool “*THERM*”, developed at Lawrence Berkeley National Laboratory, was used. Various edge constructions mounted in eight frame profiles with two different glazing systems were investigated. It was found that the box model yielded satisfactory results. The simple method based on the reference model is presented by diagrams for typical glazings and frames, and assessed to be a good alternative to the present table from “*prEN ISO 10077-1 – Part 1*”.

1. Introduction

In the work of documenting the total thermal transmittance of windows a major difficulty arises from the determination of the linear thermal transmittance (Ψ) as it depends on the glazing, the edge construction and the frame profile. The linear thermal transmittance can at present be determined in two ways:

- Simplified by use of [1] in, which a table for some combinations of glazing, edge and frame is provided.
- Detailed by use of [2] in, which the use of two-dimensional finite difference or finite element programmes are used to model the detailed construction including the spacer profile.

For both methods it would be useful to have a general characterisation of the heat transfer in the edge construction. In this way it would not be necessary to use the specific edge construction in the determination of the linear thermal transmittance.

Furthermore it would be useful to be able to use the general thermal characterisation of the edge construction in the calculation of the condensation performance based on the lowest temperature of

¹ Author to whom correspondence should be addressed. Tel.: +45 45251854; e-mail: ss@byg.dtu.dk

the window. The condensation performance is calculated according to [3]. In this standard the condensation factor (f_{Rsi}) is defined as:

$$f_{Rsi} = \frac{T_{oi} - T_u}{T_i - T_u}$$

The critical temperature (T_{oi}) is typically very dependent of the edge construction.

One of the problems in characterising the edge construction with respect to heat transfer is to get acceptable accuracy for the calculation of both the linear thermal transmittance and the condensation factor.

The aim is to develop a method for thermal characterisation of edge constructions that can be used in general for all frame profiles and glazings when performing energy labelling of windows. The characteristic value for the edge constructions is to be used for calculation of the linear thermal transmittance and the critical temperature on the lower part of the inner glazing.

The method is validated through analysis of seven typical edge constructions mounted in eight

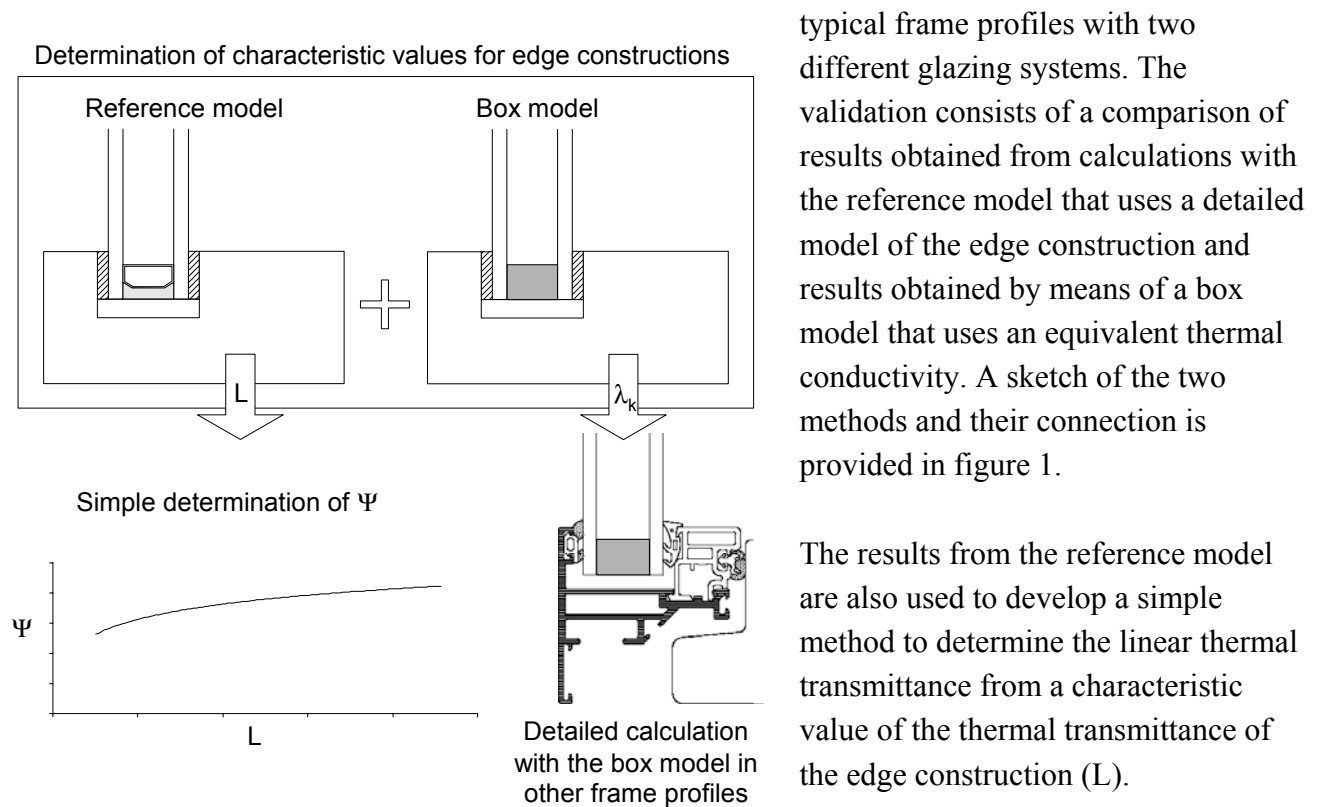

Figure 1: Sketch of the two methods.

2. Detailed method to characterise glazing edge constructions

The method is based on an equivalent thermal conductivity (λ_k) of the edge construction [4] and the calculation method described in [2]. In the following the detailed method is described step by step.

A detailed reference model of the specific edge construction is made and implemented in the wooden standard frame profile from [2] sketched in figure 3. The height of the groove is though modified from 15 mm to 13 mm because calculations performed with actual frame profiles yielded more “safe” results with respect to the linear thermal transmittance.

An example of calculations performed with the two groove heights are presented in figure 2. Two values of the equivalent thermal conductivity are found for 13 mm and 15 mm groove height. Results from the box model and the reference model implemented in frame profile A1 (appendix A1) are compared and it can be obtained that the Ψ -values with 13 mm groove height are the highest for edge construction a and c (see figure 4). An example of a “warm edge” (f) is also included and it yields that the influence of the groove height is insignificant for low Ψ -values.

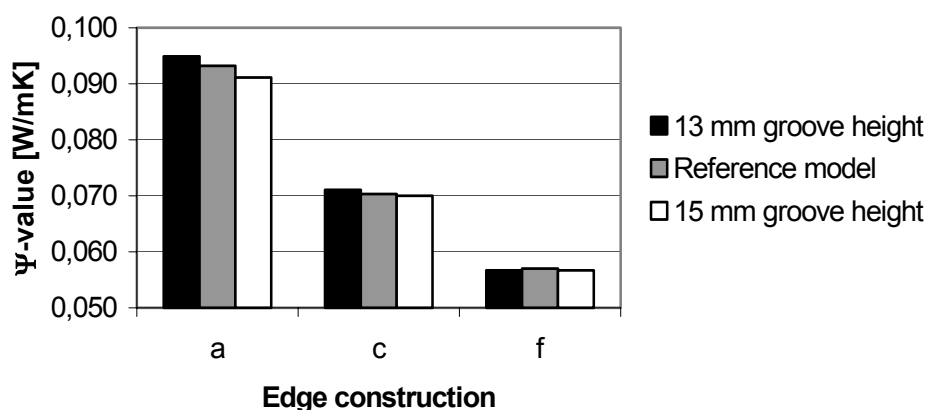

Figure 2: Influence of groove height in the wooden frame profile with aluminium glazing bead (A1).

The total heat transfer through the modelled section (figure 3) is obtained from the calculation in “THERM” (reference model).

Afterwards the detailed model of the edge construction is substituted with a box of the same dimension (box model). The thermal conductivity of this box is varied until the total heat transfer through the modelled section is the same as in the calculation with the detailed model of the edge construction. When this is achieved the current thermal conductivity is recorded and labelled the equivalent thermal conductivity (λ_k) of the specific edge construction. The edge construction is now characterised by an equivalent thermal conductivity. It is assumed that λ_k can be used in the box model for different frame profiles and glazing systems.

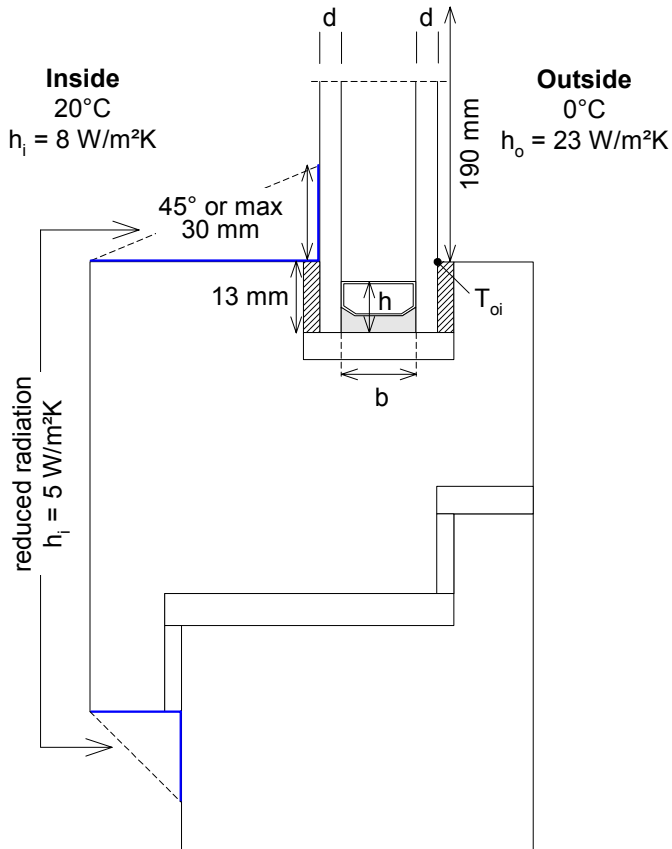

Figure 3: Sketch of the modified standard frame profile from “prEN ISO 10077-2” used to determine the equivalent thermal conductivity (λ_k) in the box-model.

The thermal transmittance (L) of the edge construction is then calculated according to:

$$L = \frac{\lambda_k}{b} \cdot h$$

This value is used as an input in the diagram developed for simple determination of the linear thermal transmittance (see figure 10).

2.1 Description of edge constructions

The edge constructions have a desiccant, which ensures that the window stays dry, and prevents condensation in the cavity. The edge constructions are tightened with a double sealing of butyl (thickness is 0.25 mm) and polysulphide (thickness is 3 mm).

The two glazing systems used in the calculations are a traditional double glazing and a double energy glazing with a glass thickness of 4 mm and a cavity filled with air respectively 90 % argon.

Table 1: Specifications of edge constructions.

Edge construction	Material
a	Aluminium
b	Galvanised steel
c	Stainless steel
d	Stainless steel
e	Plastic (pvc) with steel support
f	Plastic (reinforced polyester) with aluminium foil
g	Butyl

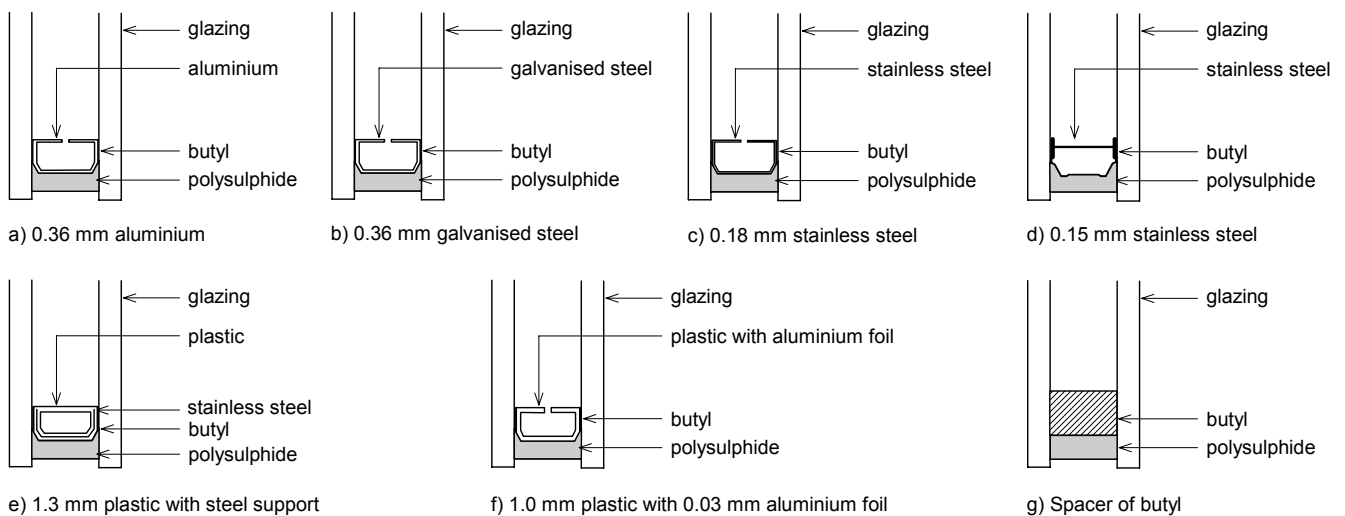

Figure 4: Sketch of the modelled edge constructions.

The results from the calculation of the equivalent thermal conductivity of the edge constructions, λ_k , are presented in table 2.

Table 2: Dimensions and thermal characterisation of the edge constructions.

Edge construction	Height, h [mm]	Width, b = 14 mm		Width, b = 15 mm		Width, b = 16 mm		Width, b = 24 mm	
		λ_k [W/m·K]	L [W/m·K]	λ_k [W/m·K]	L [W/m·K]	λ_k [W/m·K]	L [W/m·K]	λ_k [W/m·K]	L [W/m·K]
a	9.5	3.05	2.06	3.20	2.01	3.33	1.97	4.29	1.69
b	9.5	2.15	1.45	2.23	1.40	2.28	1.35	2.68	1.06
c	9.5	0.794	0.53	0.799	0.50	0.794	0.47	0.820	0.32
d	10	0.585	0.41	0.588	0.39	0.610	0.38	0.606	0.25
e	11	0.321	0.25	0.324	0.24	0.325	0.22	0.333	0.15
f	9.5	0.445	0.30	0.459	0.29	0.468	0.28	0.534	0.21
g	13	0.285	0.26	0.286	0.25	0.287	0.23	0.291	0.16

3. Validation of the detailed method (box model)

The results obtained by use of the box model are presented in the following. The edge constructions used to assess the method are described in table 1 and sketched in figure 4.

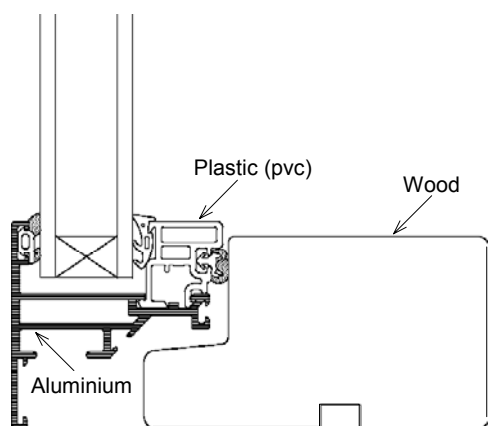

Figure 5: Sketch of the modelled frame profile made from aluminium, wood and pvc (frame profile A7).

Results obtained from calculation with an aluminium/wood/pvc frame profile (see figure 5) will be presented in the following. The profile is made for a glazing thickness of 24 mm.

This frame profile is chosen because it is quite different from the standard profile used to determine the equivalent thermal conductivity of the edge construction and therefore it should be a good test of the method.

In figure 6 and figure 7 the linear thermal transmittance (Ψ -value) and the temperature (T_{oi}) calculated by means of the reference model and the box model respectively are presented and compared.

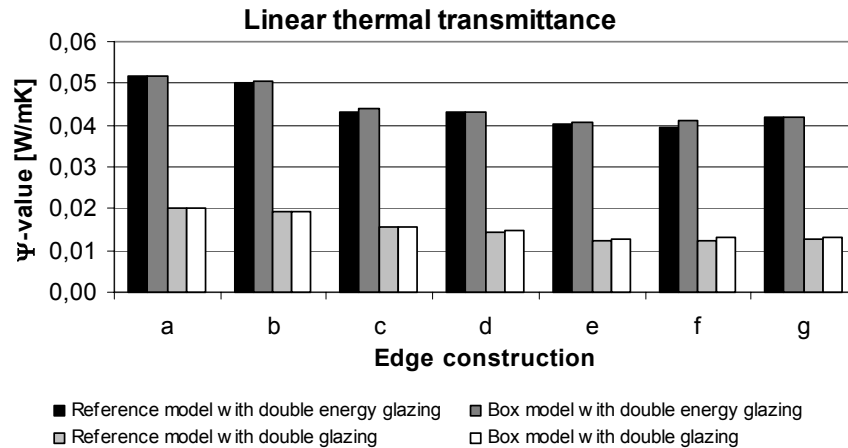

Figure 6: Linear thermal transmittance calculated for the reference model and the box model for an aluminium/wood/pvc frame profile (A7) with a double energy glazing and a double glazing.

As it can be obtained there is a good agreement between the Ψ -values calculated according to the reference and the box models respectively.

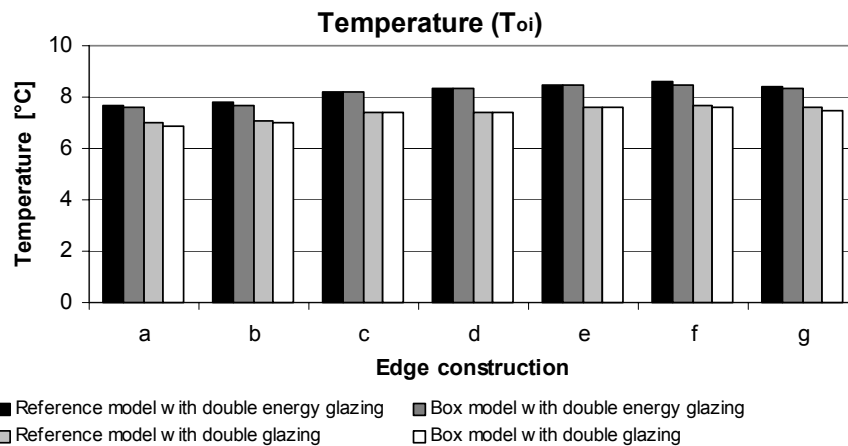

Figure 7: Temperature on the lower part of the inner glazing calculated for the reference model and the box model for an aluminium/wood/pvc frame profile (A7) with a double energy glazing and a double glazing.

Assessing the temperatures (T_{oi}) it is found that the values are more or less identical in the two models with deviations of about 0.1 K.

Further results for seven other frame profiles are placed in appendix A, where the same good agreement between Ψ -values and temperatures can be observed.

3.1 Influence of glass thickness

The influence of the glass thickness is investigated through a variation of glass thickness from 4 mm to 8 mm, which is considered to cover typical glazings. The variation is performed for three typical edge constructions.

In figure 8 the glazing thickness is varied from 4 mm to 8 mm in the wood frame profile with aluminium glazing bead (frame profile A1).

As it can be obtained from figure 8 the glass thickness has a significant influence on the linear thermal transmittance. The linear thermal transmittance is increased for a higher glass thickness, which could be expected because of the increased fin efficiency.

Furthermore it can be obtained that the box model is robust towards variations in glass thickness.

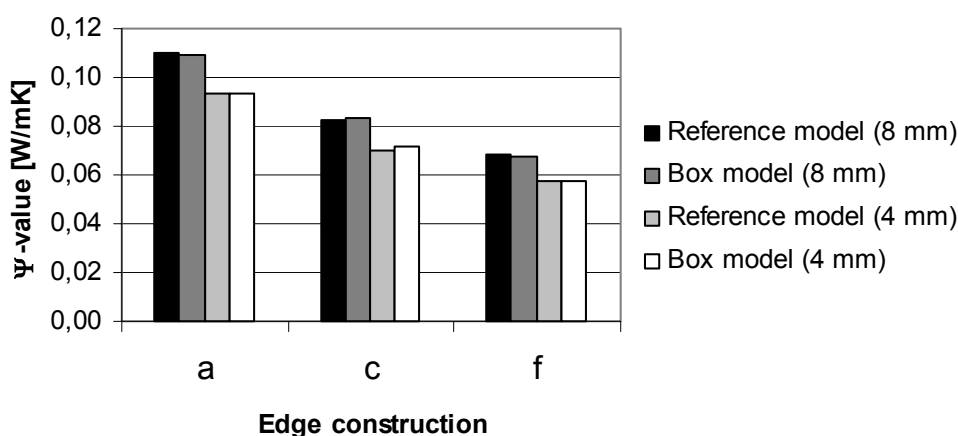

Figure 8: Variation of glass thickness from 4 mm to 8 mm in the wood frame profile with aluminium glazing bead (frame profile A1).

4. Calculation accuracy

Using the method described in this paper for determination of the equivalent thermal conductivity of the edge construction requires a high level of calculation accuracy. When comparing the total heat transfer through the standard frame profile with different edge constructions mounted, the difference between the results is relatively small. In order to achieve reliable and consistent results it is therefore very important that the computer simulation uses such a fine mesh that an increasing of the number of mesh points will not change the results significantly.

It could be discussed how many decimals the result of the equivalent thermal conductivity should be presented with. Edge constructions with large value of the equivalent thermal conductivity (above 2 W/(m·K)) have almost the same value of the linear thermal transmittance. Changes in the value of the equivalent thermal conductivity at values below 1 W/(m·K) otherwise have a significant influence on the linear thermal transmittance. It is in generally recommended that the equivalent thermal conductivity should be presented with two decimals or if very detailed results are needed three decimals.

5. Simple method to determine the linear thermal transmittance

The idea in the simple method is that a manufacturer of windows can get a general characterisation of the frame profile and then easier determine the linear thermal transmittance from the thermal characteristic value (L) for different edge constructions.

The simple method to determine the linear thermal transmittance is based on the calculations performed with the reference model. The principle in the simple method is that the linear thermal transmittance is a function of the thermal characteristic value (L) of the edge construction and the glass thickness. Diagrams that describe this relation for different frame materials and different glazing systems are developed on basis of the performed calculations on the frame profiles shown in appendix A. In figure 9 the performed calculations are presented.

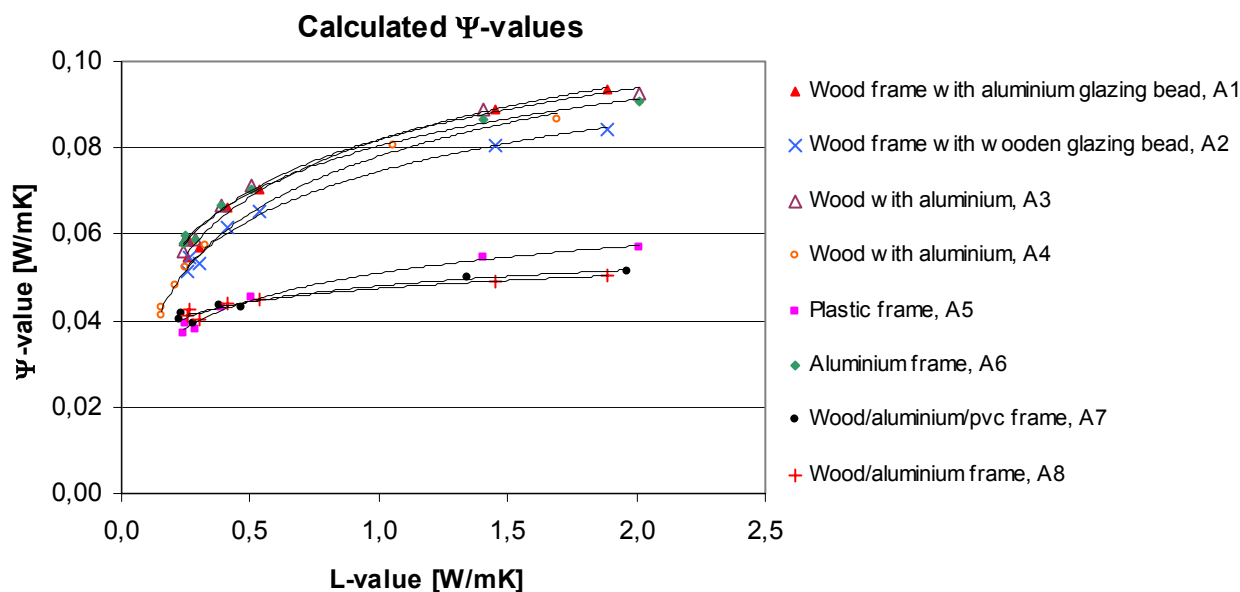

Figure 9: Calculated values of the linear thermal transmittance (Ψ -value). The diagram provides results for eight different frames as a function of the thermal transmittance (L) of the edge construction valid for a double energy glazing with a thermal transmittance applicable to the centre of the glazing (U_g) of approximately $1.2 \text{ W/m}^2\text{K}$. The frame profiles used in the calculations are shown in appendix A.

In order to develop a method for simple determination of the linear thermal transmittance the different frames could be characterised by one characteristic expression. This (see figure 10) expression is derived as the maximum values from figure 9 added 10 % in order to be valid for all frames. The diagrams in figure 10 are valid for double energy glazing with a thermal transmittance applicable to the centre of the glazing (U_g) of approximately $1.2 \text{ W/m}^2\text{K}$ and the Ψ -value can be determined for 4 mm and 8 mm glass thickness.

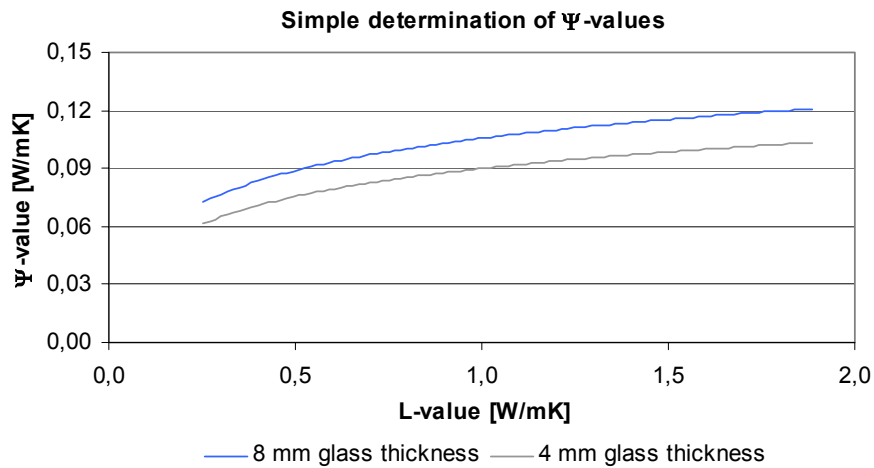

Figure 10: Diagram for simple determination of the linear thermal transmittance (Ψ -value). The diagram uses the thermal transmittance (L) of the edge construction and the glass thickness as input and is valid for a double energy glazing with a thermal transmittance applicable to the centre of the glazing (U_g) of approximately $1.2 \text{ W/m}^2\text{K}$.

6. Conclusions

It can be concluded that the box model yields sufficient accuracy for the purpose of calculating the linear thermal transmittance (Ψ) and the temperature on the lower part of the inner glazing (T_{oi}). The use of the box model makes it easier to perform detailed calculations of the linear thermal transmittance of glazing/frame junctions.

The simple method for determination of the linear thermal transmittance is developed and assessed to be a good alternative to the present table from [1], though further work might be needed in order to verify that the method is valid for other frame profiles.

Nomenclature

b	Width of spacer/air cavity	[m]
f_{Rsi}	Condensation factor	[-]
h	Height of spacer	[m]
L	Thermal transmittance of edge construction	[W/mK]
T_{oi}	Temperature on the lower part of the inner glazing	[K]
T_i	Inside temperature (293)	[K]
T_u	Outside temperature (273)	[K]
U_g	Thermal transmittance applicable to the centre of the glazing	[W/m ² K]
λ_k	Equivalent thermal conductivity of edge construction	[W/mK]
Ψ	Linear thermal transmittance of glazing/frame junction	[W/mK]

References

- [1] “EN ISO 10077-1 Thermal performance of windows, doors and shutters – Calculation of thermal transmittance – Part 1: Simplified method”
- [2] “prEN ISO 10077-2 Thermal performance of windows, doors and shutters – Calculation of thermal transmittance – Part 2: Numerical method for frames”
- [3] “EN ISO 10211-2 Thermal bridges in building construction – Heat flows and surface temperatures – Part 2: Calculation of linear thermal bridges”
- [4] IEA Task 18: “Advanced Glazing and Associated Materials for Solar and Building Applications”, Chapter 9

Acknowledgement

The work described in this paper is supported by the Danish Energy Agency, Project Window.

Appendix A

Appendix A1

Wood frame profile with aluminium glazing bead

Table A1: Simulation data

Frame	U_f	1.67	W/m^2K
Double energy glazing	U_g	1.16	W/m^2K
Double glazing	U_g	2.79	W/m^2K
Width of edge construction	b	14	mm

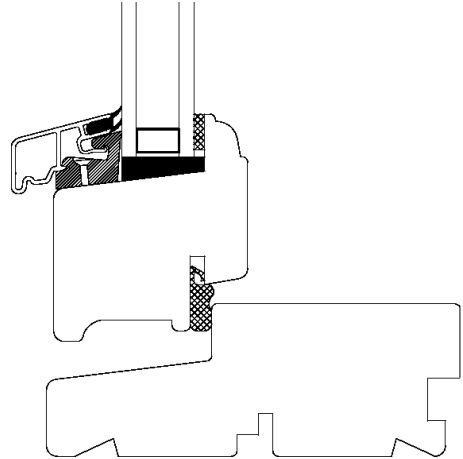

Figure A1.1: Sketch of wood frame profile with aluminium glazing bead

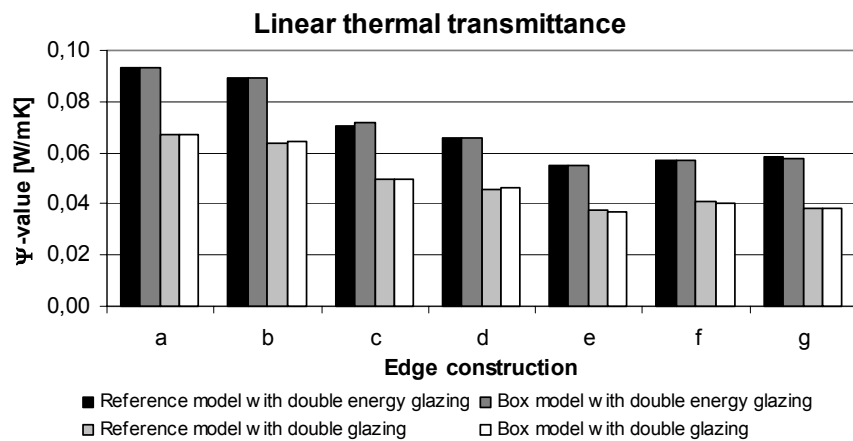

Figure A1.2: Linear thermal transmittance simulated for a wood frame profile with aluminium glazing bead (Figure A1.1)

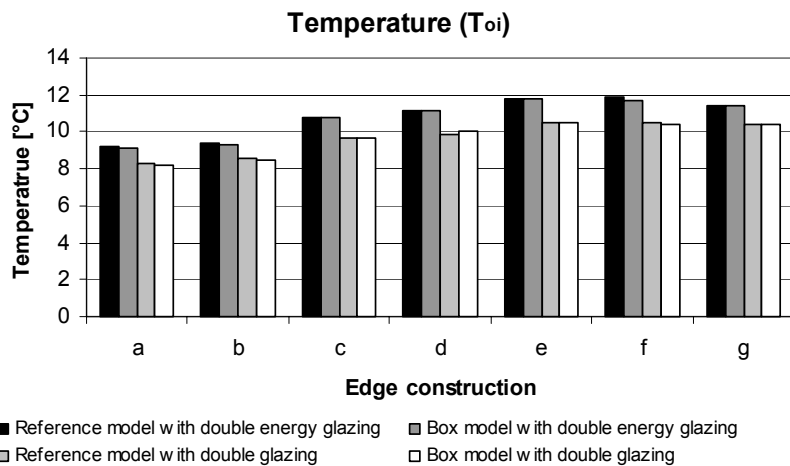

Figure A1.3: Temperature on the lower part of the inner glazing simulated for a wood frame profile with aluminium glazing bead

Appendix A2

Wood frame profile with wooden glazing bead

Table A2: Simulation data

Frame	U_f	1.53	W/m^2K
Double energy glazing	U_g	1.16	W/m^2K
Double glazing	U_g	2.79	W/m^2K
Width of edge construction	b	14	mm

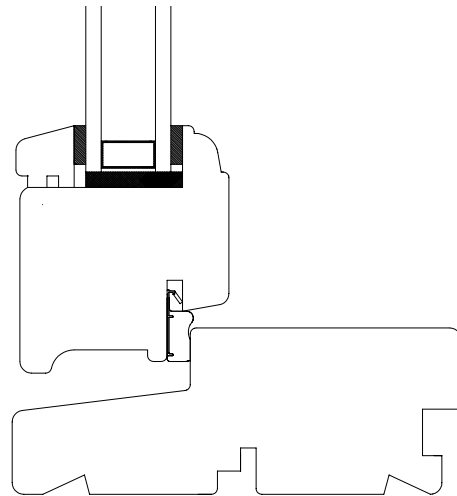

Figure A2.1: Sketch of wood frame profile with wooden glazing bead

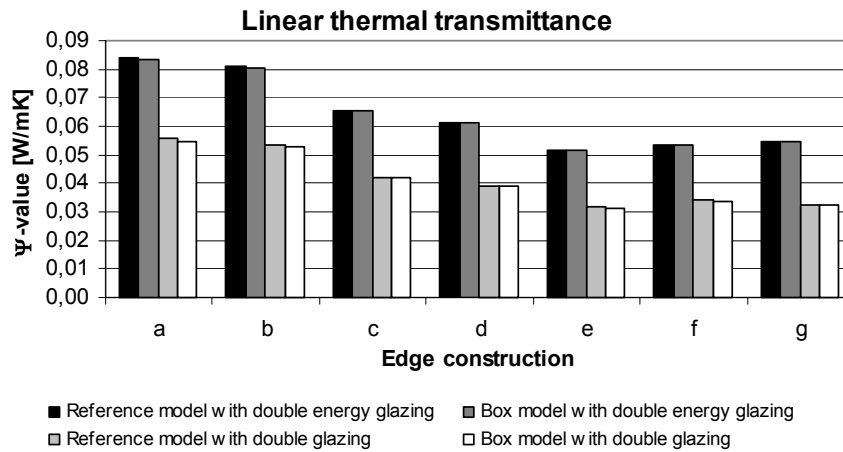

Figure A2.2: Linear thermal transmittance simulated for a wood frame profile with wooden glazing bead (Figure A2.1)

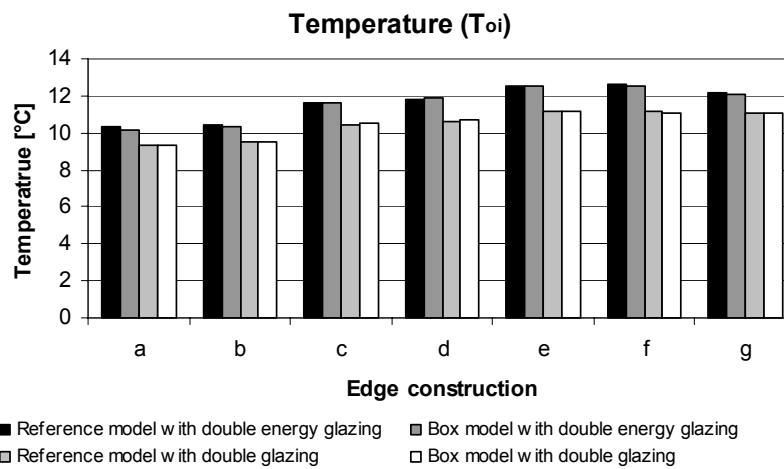

Figure A2.3: Temperature on the lower part of the inner glazing simulated for a wood frame profile with wooden glazing bead

Appendix A3

Wood/aluminium frame profile

Table A3: Simulation data

Frame	U_f	1.81	W/m^2K
Double energy glazing	U_g	1.13	W/m^2K
Double glazing	U_g	2.56	W/m^2K
Width of edge construction	b	15	mm

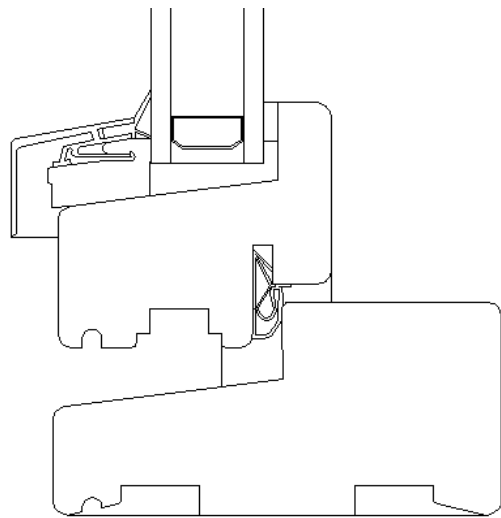

Figure A3.1: Sketch of wood/aluminium frame profile

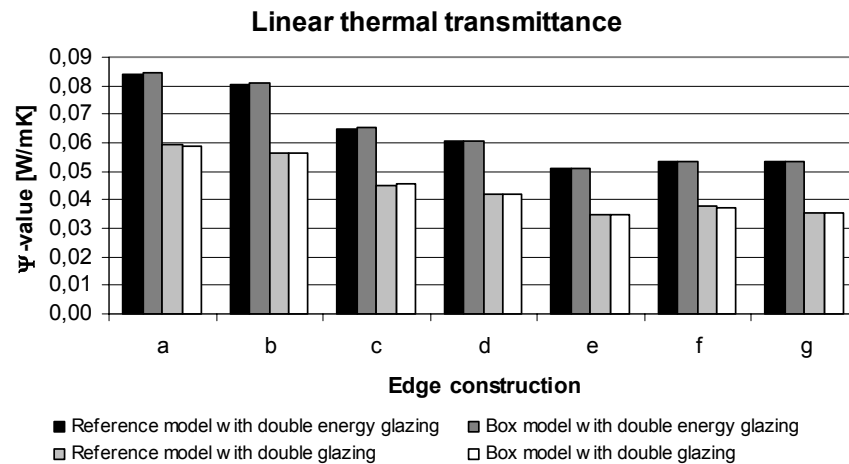

Figure A3.2: Linear thermal transmittance simulated for a wood/aluminium frame profile (Figure A3.1)

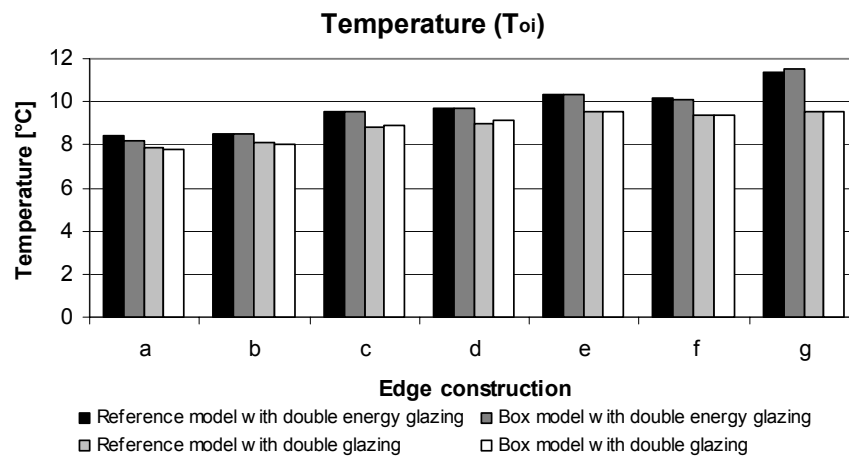

Figure A3.3: Temperature on the lower part of the inner glazing simulated for a wood/aluminium frame profile

Appendix A4

Wood/aluminium frame profile

Table A4: Simulation data

Frame	U_f	1.39	W/m ² K
Double energy glazing	U_g	1.18	W/m ² K
Double glazing	U_g	2.77	W/m ² K
Width of edge construction	b	24	mm

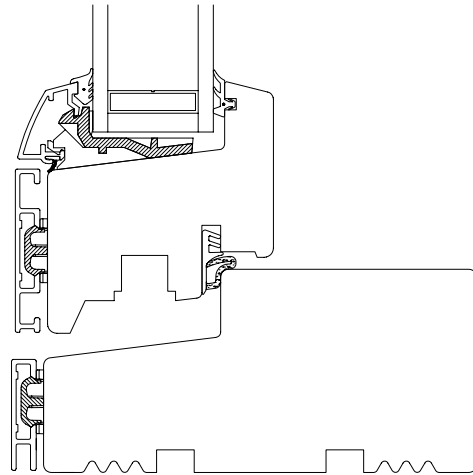

Figure A4.1: Sketch of wood/aluminium frame profile

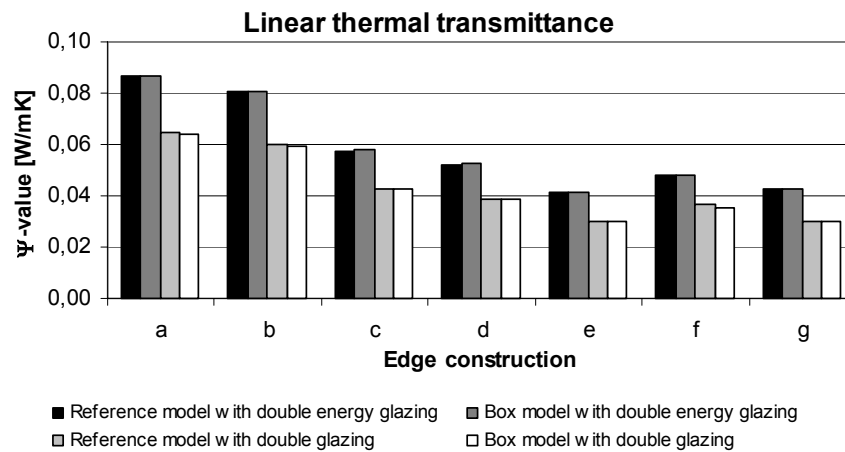

Figure A4.2: Linear thermal transmittance simulated for a wood/aluminium frame profile (Figure A4.1)

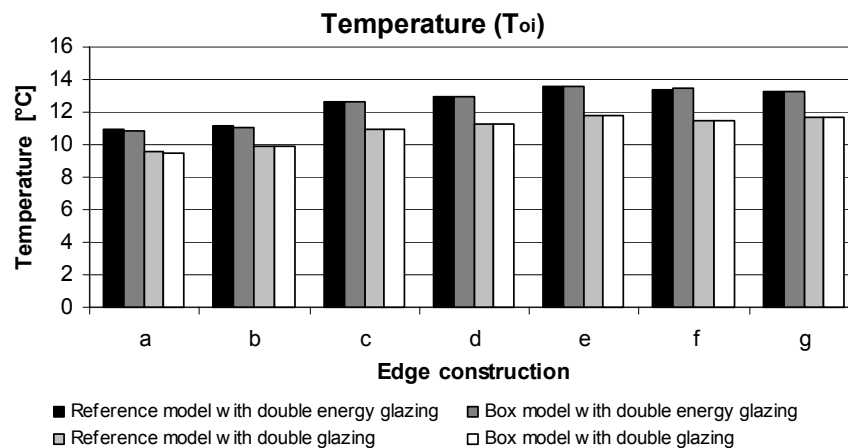

Figure A4.3: Temperature on the lower part of the inner glazing simulated for a wood/aluminium frame profile

Appendix A5

Plastic (pvc) frame profile

Table A5: Simulation data

Frame	U_f	1.71	W/m^2K
Double energy glazing	U_g	1.13	W/m^2K
Double glazing	U_g	2.76	W/m^2K
Width of edge construction	b	15	mm

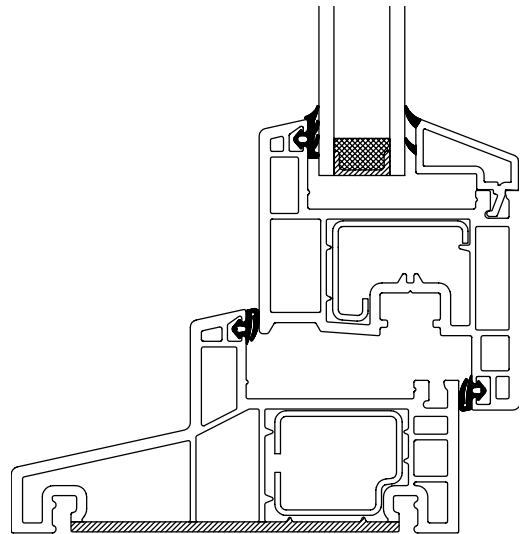

Figure A5.1: Sketch of plastic (pvc) frame profile

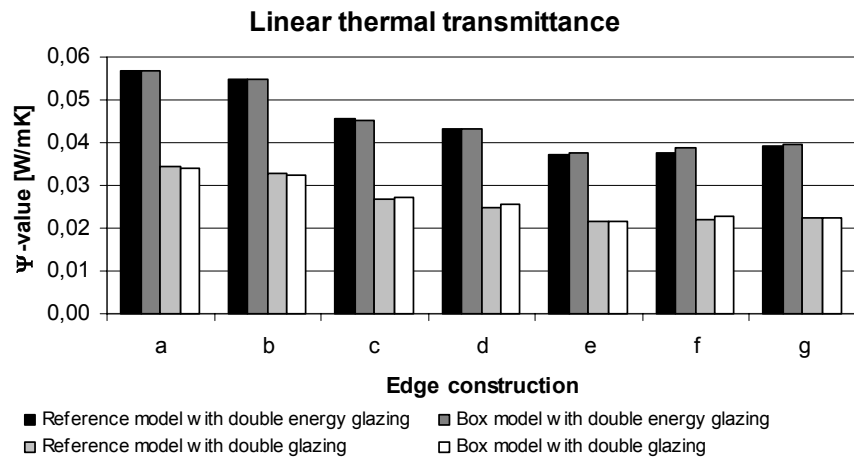

Figure A5.2: Linear thermal transmittance simulated for a plastic frame profile (Figure A5.1)

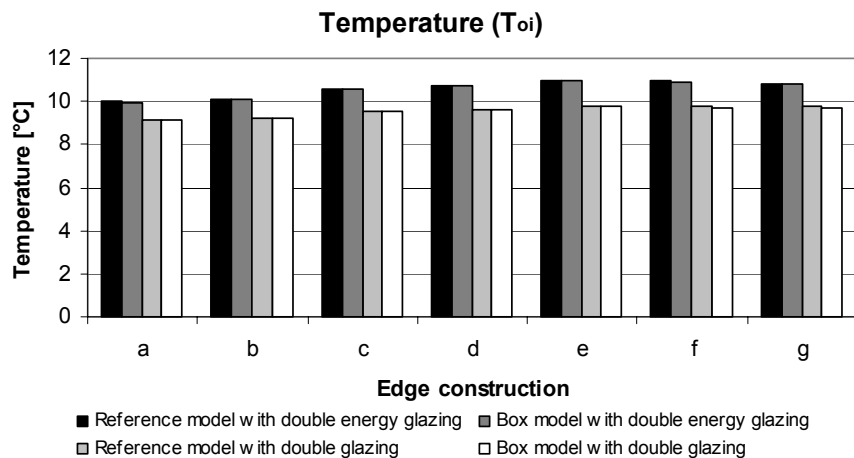

Figure A5.3: Temperature on the lower part of the inner glazing simulated for a plastic frame profile

Appendix A6 Aluminium frame profile

Table A6: Simulation data

Frame	U_f	3.46	W/m^2K
Double energy glazing	U_g	1.13	W/m^2K
Double glazing	U_g	2.76	W/m^2K
Width of edge construction	b	15	mm

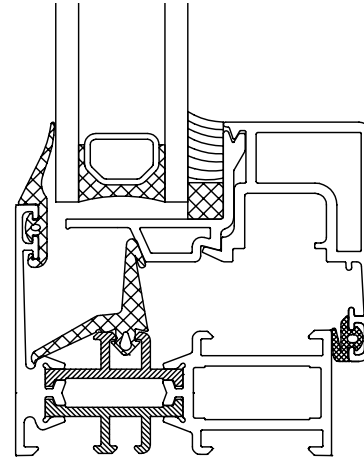

Figure A6.1: Sketch of aluminium frame profile

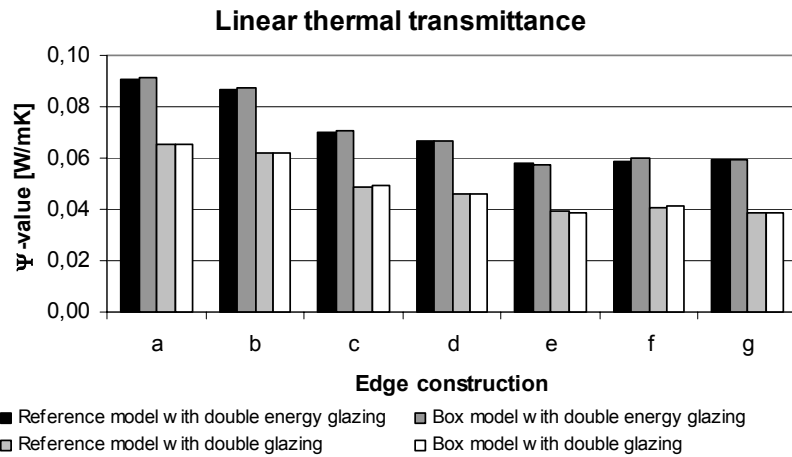

Figure A6.2: Linear thermal transmittance simulated for a aluminium frame profile (Figure A6.1)

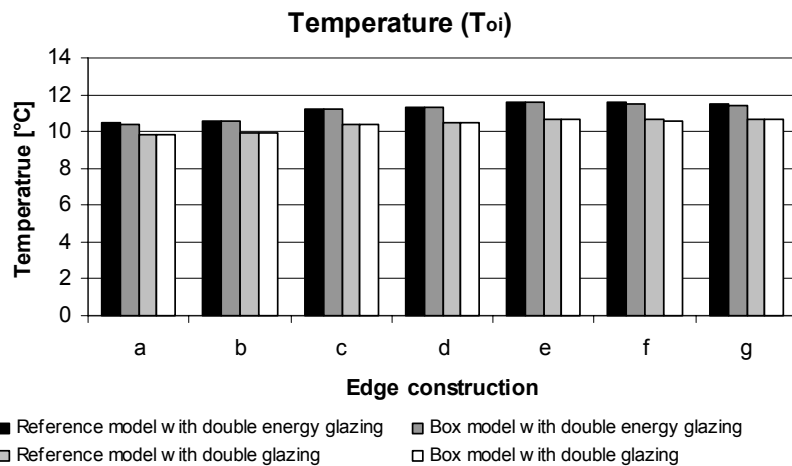

Figure A6.3: Temperature on the lower part of the inner glazing simulated for a aluminium frame profile

Appendix A7

Wood/aluminium/pvc frame profile

Table A7: Simulation data

Frame	U_f	2.78	W/m^2K
Double energy glazing	U_g	1.14	W/m^2K
Double glazing	U_g	2.74	W/m^2K
Width of edge construction	b	16	mm

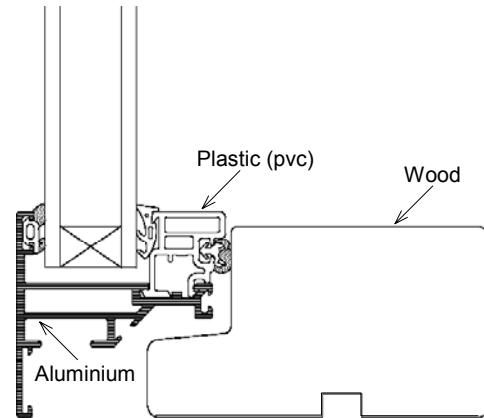

Figure A7.1: Sketch of wood/aluminium/pvc frame profile

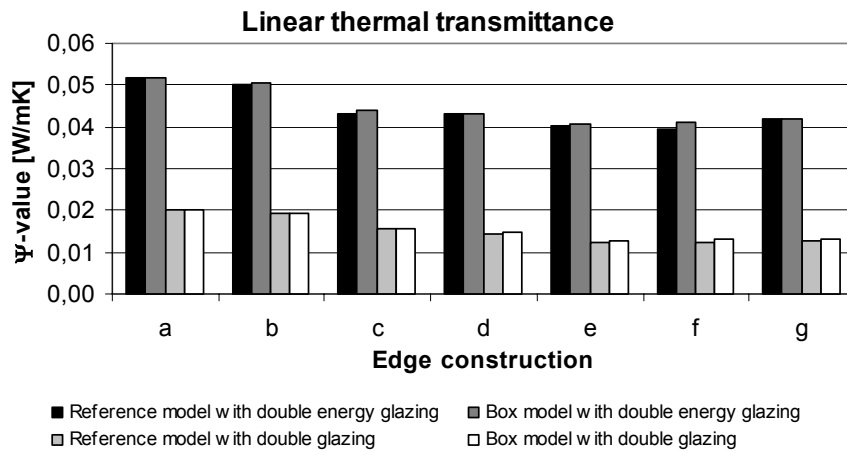

Figure A7.2: Linear thermal transmittance simulated for a wood/aluminium/pvc frame profile (Figure A7.1)

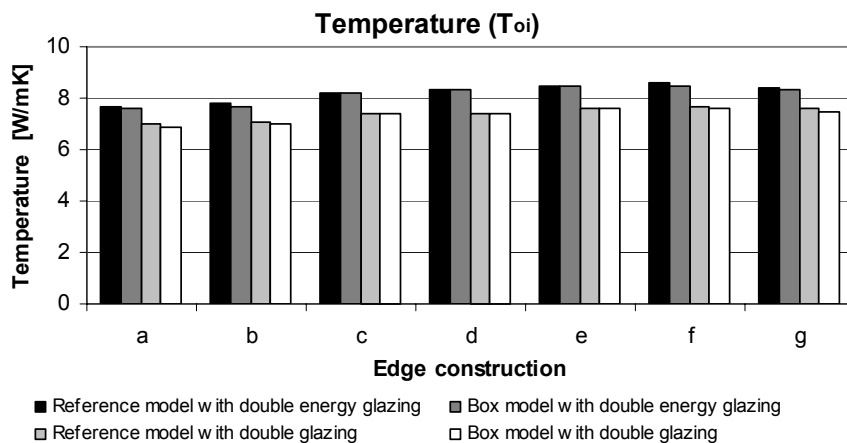

Figure A7.3: Temperature on the lower part of the inner glazing simulated for a wood/aluminium/pvc frame profile

Appendix A8

Wood/aluminium frame profile

Table A8: Simulation data

Frame	U_f	3.42	W/m ² K
Double energy glazing	U_g	1.16	W/m ² K
Double glazing	U_g	2.79	W/m ² K
Width of edge construction	b	14	mm

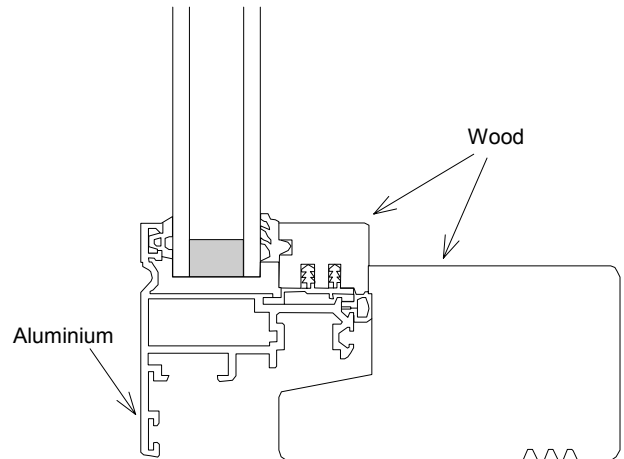

Figure A8.1: Sketch of wood/aluminium frame profile

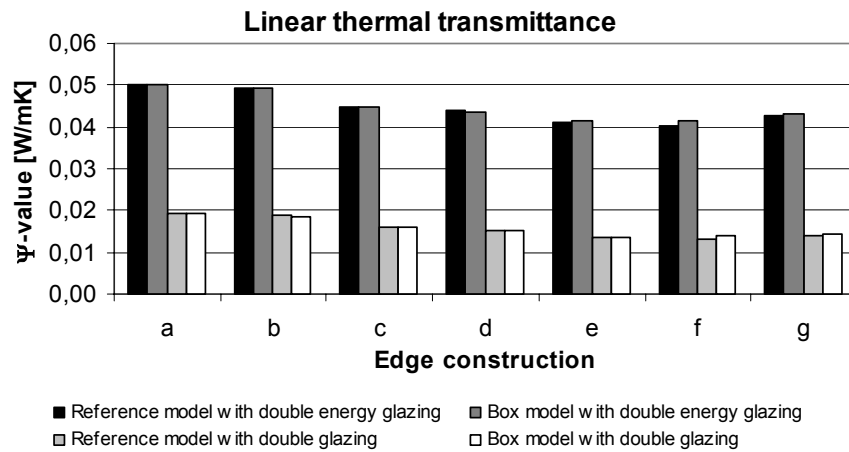

Figure A8.2: Linear thermal transmittance simulated for a wood/aluminium frame profile (Figure A8.1)

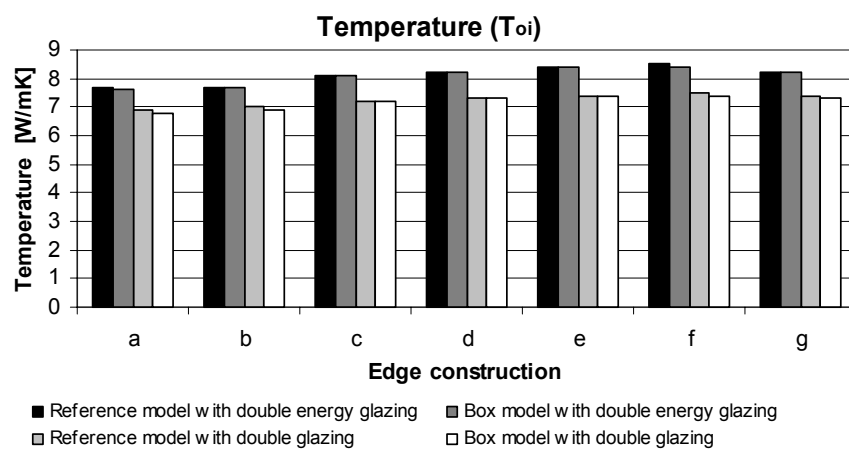

Figure A8.3: Temperature on the lower part of the inner glazing simulated for a wood/aluminium frame profile